

# **ENGINEERING AND DEVELOPMENT GUIDELINES**



*Community, Environment  
& Industry in Partnership*



## **SEWERAGE**

## **DESIGN**

## **STANDARD 2003**

**Revised :Aug 2002**

**Incorporates the WSAA "Sewerage Code of Australia"**

(Blank Page)

## **SEWERAGE DESIGN STANDARDS**

These guidelines apply to the design and construction of sewerage works for development works within Calliope Shire Council and Gladstone City Council.

The Water Services Association of Australia's "*Sewerage Code of Australia*" (1999) forms a part of and is to read as one with this Standard. . This Standard gives the provisions required over and above this Code. This "*Sewerage Code of Australia*" (SCOA) is now being adopted as a default IPA code by the Queensland Government. The document can be obtained from the following sources:

Water Services Association of Australia  
469 Latrobe Street  
Melbourne Victoria 3000

Standards Australia  
1 The Crescent  
Homebush NSW 2140

The distribution of these standards does not limit Council's authority to impose additional or alternative requirements, if such requirements are warranted having regard to the particular circumstances of a subdivision and good engineering practice.

Where Australian Standards, By-laws, manufacturer's recommendations, or other publications are referred to in these standards, the latest revision of such documents shall be used.

Council produces these standards to simplify the documentation of sewerage projects. Council will not accept standards from other authorities where a Council standard is available. It is expected that contractors will be issued with sufficient copies of these standards and drawings for each project such that a set are immediately available on site.

(Blank Page)

# **SEWERAGE DESIGN STANDARD**

## **TABLE OF CONTENTS**

<b>DESIGN.....</b>	<b>5</b>
<b>1 GENERAL.....</b>	<b>5</b>
1.1 OBJECTIVES OF SEWERAGE WORKS FOR DEVELOPMENT.....	5
1.2 SEWERAGE AGENCY.....	5
<b>2 DESIGN.....</b>	<b>2</b>
2.1 LAYOUT & ALIGNMENT.....	2
2.2 PIPE SIZE.....	2
2.3 PIPE GRADE.....	2
2.4 MAINTENANCE STRUCTURES.....	2
2.4.1 MAINTENANCE HOLE LOCATION.....	3
2.4.2 DEPTH OF MAINTENANCE HOLES.....	3
2.4.3 TERMINAL MAINTENANCE SHAFTS.....	4
2.5 MISCELLANEOUS DESIGN FEATURES.....	4
2.5.1 WATER SEALS.....	4
2.5.2 INVERTED SYPHONS.....	4
2.5.3 BULKHEADS AND TRENCH STOPS.....	4
2.6 SEWER CONNECTIONS.....	4
2.7 DRAWING REQUIREMENTS.....	4
2.8 FLOW ESTIMATION.....	5
2.9 PUMP STATIONS.....	5
<b>MATERIALS.....</b>	<b>5</b>
1.1 PIPES & FITTINGS.....	5
1.1.1 DUCTILE IRON.....	5
1.1.2 CONCRETE PIPES.....	6
1.1.3 GIBALT JOINTS.....	6
1.2 PRE-CAST CONCRETE MAINTENANCE HOLES.....	6
1.3 LIDS AND FRAMES.....	6
1.4 CONCRETE & STABILISED SAND.....	6
1.5 EMBEDMENT MATERIAL.....	6
<b>STANDARD DRAWINGS.....</b>	<b>8</b>
<b>CONSTRUCTION.....</b>	<b>9</b>
1.1 LICENSED PERSONS.....	9
1.2 INSPECTIONS AND TESTING VISUAL.....	9
1.2.1 INSPECTIONS.....	9
1.2.2 TESTING.....	9
1.3 MATERIALS.....	9
1.3.1 SEWER EMBEDMENT.....	9
1.3.2 PIPE AND MATERIAL SPECIFICATIONS.....	10
1.4 EXISTING SERVICES.....	10
1.5 EXCAVATION.....	10
1.5.1 TRENCHING.....	10
1.6 PIPE LAYING AND JOINTING.....	11
1.6.1 PIPE LAYING & JOINING.....	11
1.6.2 JUNCTIONS, PROPERTY CONNECTIONS SEWERS, INSPECTION OPENINGS.....	12
1.6.3 INVERTED SYPHONS, WATER SEALS AND VERTICAL RISERS.....	12
1.6.4 DEAD ENDS.....	12
1.6.5 MARKING OF PROPOERTY CONNECTIONS.....	12
1.6.6 DETECTABLE TAPE.....	12
1.6.7 BACKFILLING.....	13
1.7 MAINTENANCE HOLES.....	13
1.7.1 MAINTENANCE HOLE CONNECTIONS.....	13
1.7.2 MAINTENANCE HOLE BASES.....	13
1.7.3 MAINTENANCE HOLE WALLS.....	14
1.7.4 CONVERTER SLABS AND MAKE-UP RINGS.....	14
1.7.5 MAINTENANCE HOLE COVERS AND FRAMES.....	15

1.7.6	BACKDROPS .....	15
1.7.7	BACKFILLING MAINTENANCE HOLES .....	16
1.8	TERMINAL MAINTENANCE SHAFTS.....	16
1.9	TOLERANCES ON AS CONSTRUCTED WORK.....	16
1.10	FILLING.....	16
1.11	RESTORATION & CLEAN UP.....	16
1.12	EXISTING SEWERS.....	16
1.13	"AS CONSTRUCTED" DETAILS.....	17
1.14	SUB-SOIL DRAINAGE .....	17
1.15	ROAD CROSSINGS .....	17
1.16	WATER COURSES.....	18
<b>2</b>	<b>OTHER REQUIREMENTS.....</b>	<b>18</b>
2.1	ENTRY ONTO PRIVATE LAND.....	18
2.2	INSPECTION AUDITS .....	18
2.3	CERTIFICATION BY SUPERVISING CONSULTING ENGINEER.....	19
2.4	MAINTENANCE PERIODS.....	19
	APPENDIX A – Design and Construction Proforma.....	20
	SEWERAGE DESIGN CHECKLIST .....	21
	APPENDIX B – Standard Drawings.....	25



# DESIGN

## 1 GENERAL

Sewer reticulation shall be provided in accordance with the Standard Sewerage Laws, relevant Australian Standards and any specific requirements of Council.

The design and construction will generally be in accordance with the Water Services Association of Australia's "Sewerage Code of Australia" (SCOA) as amended by Council's Standard and standard drawings which takes precedence over the SCOA.

Domestic sewers will require considerable reference to this standard as this is the predominant type of sewer laid. The configuration of larger sewers will more than likely follow the SCOA requirements.

### 1.1 OBJECTIVES OF SEWERAGE WORKS FOR DEVELOPMENT

Council's objectives of sewer construction is to provide a *high quality, free draining, zero infiltration* system produced to a *high level of workmanship* which will provide the rate payers of the shire with an efficient low-maintenance system with a minimum of stores inventory required for repair works.

### 1.2 SEWERAGE AGENCY

The Sewerage Agency for sewerage works within the Calliope Shire is the Calliope Shire Council and Gladstone City Council within Gladstone City.

## 2 DESIGN

The design and layout of the sewerage scheme should be generally in accordance with the Council's Total Management Plan for Sewerage and the SCOA as amended by the following. Engineering plans are required to be prepared and certified by a registered Professional Engineer of Queensland.

### 2.1 LAYOUT & ALIGNMENT

Sewer reticulation shall be arranged to minimise the length of sewer line in private property by locating sewer lines within the road reserve wherever possible. Such lines shall be located parallel to and 2.4 metres from the front property boundary.

Sewer lines shall run parallel to and 1.5 metres from the property boundary when located within private property. The tolerance on the alignment of the centre of the pipe shall be  $\pm 0.1\text{m}$ .

Sewer lines shall cross property boundaries as near as possible to 90 degrees, and where possible should be designed such that not more than one sewer line and one maintenance hole shall be located within any one allotment.

Easements are not normally required for sewer lines however Council reserves the right to require an easement over any sewer line through any lot in the reconfiguration.

Curved sewers will not be used unless otherwise arranged with the Sewerage authority.

A preliminary design of future stormwater systems may be required to minimise clashes of gravity pipe lines.

### 2.2 PIPE SIZE

Trunk mains shall be sized as per Council's "Total Management Plan - Sewerage" or as per other approved network analysis.

The minimum size of sewerage line shall be as per SCOA.

Sewers greater than 225mm diameter which are required by Council to be larger than that required by the demand of the development may be eligible for oversizing contributions from Council.

### 2.3 PIPE GRADE

The minimum grade for sewer lines connecting *terminal maintenance shafts* shall be 1 in 100, with all other minimum sewer gradients to be in accordance with the SCOA. Sewers shall be designed on gradients such that the minimum velocity on a normal dry weather day exceeds 0.3metres/second.

### 2.4 MAINTENANCE STRUCTURES

All sewer lines shall be terminated either at maintenance holes or terminal maintenance shafts.



## SEWERAGE DESIGN STANDARD

---

The materials and construction details for maintenance holes for Council are significantly different to the SCOA standards with details contained on Council standard drawing SDS-02. Council requires a product with a easily proven level of quality and as such requires pre-cast walls and fibreglass bases in maintenance holes to 1500mm diameter. Drops through maintenance holes with fibre glass bases shall be as per the standard manufactured item, but no less than 20mm.

Maintenance shafts or dead ends are generally not permitted to be used on Council sewer lines with the exception of terminal maintenance shafts.

Stub lines shall terminate between 1m and 1.5m from the maintenance hole with a approved sealed cap.

### 2.4.1 MAINTENANCE HOLE LOCATION

The centre of maintenance holes within allotments shall be located 1.5 metres from the boundary crossed by the sewer line. Maintenance holes in footpaths should be located in line with the property boundary wherever possible.

The minimum maintenance hole diameter shall be 1050mm for pipes up to 225mm diameter, and 1500mm for pipes greater than 225mm diameter or where the change of direction for a sewer line is greater than 100 degrees. Where two internal drops are contained in the maintenance hole the diameter of the maintenance hole shall be 1500mm.

Spacing of maintenance holes shall be in accordance with Section 2.9.2 of the SCOA.

### 2.4.2 DEPTH OF MAINTENANCE HOLES

The minimum depth of maintenance hole with a 600mm diameter *round lid*, measured from the top of the maintenance hole to the deepest invert shall be 900mm (minimum 300mm wall section). should there be a requirement for maintenance holes of a lesser depth, Council requires the proponent to lodge an application in writing, prior to the submission of the engineering plans for the development.

The minimum depth of maintenance holes *with an internal diameter greater than 1050mm*, measured from the top of the maintenance hole to the deepest invert, shall be 1200mm.

*Rectangular lids* shall not be used on maintenance holes as they do not provide a gas tight seal to the lid of the maintenance hole and are hard to source locally.

In order to reduce the need to break pre-cast wall sections, maintenance hole depths from the invert of the down stream pipe to the top of the maintenance hole, should be 900mm, or any 150mm increment of this height. This creates a better seal on the top of the maintenance hole helping to prevent infiltration into the sewers.

In maintenance holes deeper than 6m, Council may require landings and ladders in accordance with AS1657.

---

**SEWERAGE DESIGN STANDARD**

---

**2.4.3 TERMINAL MAINTENANCE SHAFTS**

Terminal maintenance shafts may be used where the length of the line from the downstream maintenance hole is less than 45 metres, provided not more than two (2) property connections are made in the line.

Terminal maintenance shafts within allotments shall be located 1.5m from the boundary crossed by the sewer line. Terminal maintenance shafts in footpaths shall be located in line with the property boundary wherever possible. Refer Council Standard drawing SDS-02.

**2.5 MISCELLANEOUS DESIGN FEATURES****2.5.1 WATER SEALS**

Water seals will not be required by Council on branch sewers entering trunk sewers. Water seals are not allowed on property connections to trunk sewers.

**2.5.2 INVERTED SYPHONS**

Inverted syphons on trunk sewers are generally not permitted, except where express written permission of Council.

**2.5.3 BULKHEADS AND TRENCH STOPS**

Bulkheads shall be provided as per the SCOA. Trench stops will not be required, provided sub soil drainage is provided at low points discharging to an approved point.

**2.6 SEWER CONNECTIONS**

Where the sewer line is located outside the allotment being serviced, the oblique junction shall be located so that the property connection can be laid as directly as possible ie 90degrees to a point 1.0 metre inside the front and side boundaries, or the rear and side boundaries as appropriate. Not more than two bends in the property connection shall be used to reach this point. House connection branches should not be deeper than 1.5m unless additional depth required to service the property.

Invert levels for property connection branches shall be shown on the design plan and marked on the long section. Refer Council standard drawing SDS-03 for details of property connection types.

Oblique junctions shall be used but "Y" connections are not permitted.

Partial lot service shall be as determined by Council.

**2.7 DRAWING REQUIREMENTS**

Drawings should contain adequate information to allow Council to easily audit the design and construction of the sewerage infrastructure generally in accordance with Section 5 of the SCOA. House connection branches shall be shown on the long section of each line indicated by a cross and a branch invert level. Finished surface levels shall be shown on the plan with adequate detail so that Council can ascertain the control of each allotment.

## SEWERAGE DESIGN STANDARD

The recording and presentation of "as constructed" information shall be as per the relevant development control document specified by Council.

### 2.8 FLOW ESTIMATION

Flow estimation shall be as determined by Council with the average residential unit in the shire generating 250 litres per day with a wet/dry flow ratio of 3. Refer to the Department of Natural Resources and Mines' "Guidelines for Planning and Design of Sewerage Schemes" Volume 1 for further guidance in this regard.

### 2.9 PUMP STATIONS

The number of pump stations shall be minimised by the arrangement of gravity sewers or earthworks where practical. Premature or out of sequence development will not be accepted as a reason for the installation of a pump station should a gravity solution be available.

The design of pump stations will generally be carried out by Council at no cost the developer. Pumps, systems, fittings and switch boards shall be selected to integrate with and minimise the cost of Council's maintenance systems.

## MATERIALS

As this area is reasonably remote, the types of materials utilised in sewer mains should be limited such that the availability of spares is maximised and the inventory of spares carried by repair crews and Council stores is minimised. Therefore the following materials are recommended.

A higher class of pipe is required for sewer lines in subdivision developments as the depth of fill over the pipe can vary significantly with building earthworks without due consent of Council. A minimum of Class SN8 or equivalent is therefore required.

### 1.1 PIPES & FITTINGS

The standard type of pipe used by Council for domestic sewers is plain wall uPVC class SN8 sewer spigot-socket with elastomeric seal (rubber ring) or equivalent. Other types of pipe may be used for special applications.

#### 1.1.1 DUCTILE IRON

Ductile iron pipes are not preferred for general use, but if necessary shall be Class K12, cement lined, with "Tyton" type joints, elastomeric seal, complying with AS 2280, laid to AS2566.2.

All pipes shall be sleeved with "lay flat" polyethylene sleeving installed in accordance with AS 3680 & 3681 or the pipe manufacturers recommendations. Ductile Iron shall not be used under ground below RL 5.0 unless soil testing eliminates the presence of acid sulphate soils in the trenches within 100mm of the pipe.

---

**SEWERAGE DESIGN STANDARD**

---

**1.1.2 CONCRETE PIPES**

Concrete pipes are not preferred for general use.

**1.1.3 GIBALT JOINTS**

If gibault joints are used to join uPVC pipes, **long barrel** gibaults with stainless steel (Grade 316) nuts, bolts and washers shall be used. If gibaults are to be used below RL5.0 or in the presence of active or potential acid sulphate soil, measures shall be stated on the plans to satisfactorily combat the corrosion of metal parts in the joint..

**1.2 PRE-CAST CONCRETE MAINTENANCE HOLES**

Sewer maintenance holes shall be constructed using pre-cast reinforced concrete wall sections, converter slabs, make-up rings and tops. Refer standard drawing SDS-02 for details. The minimum thickness of wall sections shall be 64mm.

Concrete shall contain a minimum of 400kg/cubic metre of cement, have a maximum water:cement ratio of 0.45, and a maximum aggregate size of 10mm. The minimum concrete strength shall be 25 MPa and the cement used shall be Sulphate Resistant Portland Cement to A.S.1315.

Pre-cast concrete shall be of high quality, dense and hard with interior and exterior surfaces smooth and impervious, and free of damage and cracks. Any pre-cast component (including fibreglass base liners) which is damaged, cracked, cut, or flawed shall not be used.

Cast-in-situ maintenance hole sections shall not be used with the exception of make up rings used to level the top of the maintenance hole parallel to the finished surface profile. The maximum height of this section shall be 120mm.

Step irons or ladders are not to be installed in maintenance holes unless noted otherwise on Council's standard drawing.

**1.3 LIDS AND FRAMES**

Lids and frames shall comply with AS 3996 and be generally as per Council standard drawing SDS-02. Lids are to be marked "San Sew" – refer later section.

**1.4 CONCRETE & STABILISED SAND**

Only ready-mixed concrete and stabilised sand shall be used. Ready-mixed concrete shall comply with AS 1379 and have a minimum compressive strength of 25MPa.

Stabilised sand shall contain 4% cement mix by weight, grading to comply with the bedding material clause following.

**1.5 EMBEDMENT MATERIAL**

All material used to embed and surround sewer pipes shall be washed sand, free of organic and foreign matter, complying with the grading limits in Section 4 of Part 4 of SCOA.

**SEWERAGE DESIGN STANDARD**

---

Where pipes are installed below RL5.0 or are likely to be in contact with actual or potential acid sulphate soils, pipes shall be bedded using a limestone crusher dust material complying with the above grading in order to neutralise any acid run off from contacting concrete components such as maintenance holes.

## SEWERAGE DESIGN STANDARD

## STANDARD DRAWINGS

The following table indicates the appropriate use of Council and SCOA standard drawings.

Status of SCOA Drawings is per the following key:

Use:	Use as Council standard practice ( as amended)
Secondary:	Used to support Council Standard Drawings and Code
Optional:	May be used if specified (or prior permission obtained) by Council

<b>Council Standard</b>	<b>Topic</b>	<b>SCOA Standard</b>	<b>SCOA Status</b>
<u>SDS-01</u>	<u>Trench/backfill</u>	<u>SEW-100</u>	<u>Secondary</u>
SDS-01	Embedding support	SEW-101	Optional
	Embed/pipe support	SEW-102	Optional
→	Trenchstop+bulkheads	SEW-103	Use
	Trench Drainage	SEW-104	Secondary
	Syphon Creek crossing	SEW-105	Optional
	Aqueduct	SEW-106	Optional
	Protection Grill	SEW-107	Optional
<u>SDS-02</u>	<u>Precast Maint hole</u>	<u>SEW-201</u>	<u>Do not use</u>
SDS-02	Insitu Maint Hole	SEW-202	Do not use
SDS-02	MH base arrangement	SEW-203	Do not use
SDS-02	MH base +work area	SEW-204	Do not use
SDS-02	MH channel detail	SEW-205	Do not use
SDS-02	Internal drop	SEW-206	Do not use
→	Access covers	SEW-207	Use
	Step irons and ladders	SEW-208	Do not use
	Maintenance shaft	SEW-209	Do not use
SDS-02 or	Terminal Maint shaft	SEW-210	Use
	Mains vertical risers	SEW-211	Optional
	Access Shaft covers	SEW-212	Use
	Venting arrangement	SEW-213	Optional
	Water Seals	SEW-214	Secondary
<u>SDS-03</u>	<u>Property Connect- Priv</u>	<u>SEW-300</u>	<u>Do not use</u>
SDS-03	Property Connect-road	SEW-301	Do not use
SDS-03	Property Connect	SEW-302	Do not use
SDS-03	Property connect	SEW-303	Do not use
SDS-03	Prop Conn- temp location	SEW-304	Do not use

---

**SEWERAGE DESIGN STANDARD**

---

**CONSTRUCTION**

Construction of sewerage systems shall be generally in accordance with Part 4 of SCOA.

**1.1 LICENSED PERSONS**

Installation of sewer pipes and fittings shall be carried out by appropriately qualified persons. eg holder of a Drainers License or an Interim Drainers License granted by the Plumbers, Drainers and Gas Fitters Examination Board of Queensland or as per Section 2.1 of Part 4 of SCOA.

**1.2 INSPECTIONS AND TESTING VISUAL****1.2.1 INSPECTIONS**

Inspections of sewer lines shall be carried out by Council at the excavation stage when the sand bedding and bulkheads to Council requirements have been put in place. Council requires at least twenty four (24) hours prior notice for each inspection. At this inspection, the depth of sand bed over the pipe and alignment and straightness of the line (mirrored) will be checked by the supervising engineer and audited by Council.

At the off maintenance inspection, all sewer lines shall be subject to internal visual inspection by means of lights and/or mirrors. The lines shall appear **perfectly** straight and it shall be possible to see a full circle of light at the far end. No ponding shall be visible in any part of the sewer.

Lines which Council considers do not comply with the requirements may be required to undergo further testing in accordance with Section 2.3.5 of Part 4 of SCOA.

**1.2.2 TESTING**

Sewers shall be subject to low pressure air tests carried out in accordance with Section 2 of Part 4 of SCOA.

Sewers which run under roads shall be pressure tested before the pavement is constructed.

Because of the high level of sealing (megapoxy joints) carried out on Council's maintenance hole system pressure tests are not usually required unless Council suspects that they may not be adequately sealed.

If Council considers that any maintenance hole may not be adequately sealed, the maintenance hole shall be tested in accordance with SCOA.

**1.3 MATERIALS****1.3.1 SEWER EMBEDMENT**

Materials used in embedment should be as per Section 4 of Part 4 of SCOA.

## SEWERAGE DESIGN STANDARD

---

Under most circumstances all sewer bedding shall be washed sand for a minimum of 75mm clear below the pipe, and a full sand surround with a minimum overlay of 200mm over the pipe.

Compaction shall be to 90% of maximum modified dry density as determined by Part E2.1 of Australian Standard AS 1289, "Methods of Testing Soil for Engineering Purposes". The sand surround shall be carefully placed adjacent to and over the pipe and then compacted to a depth of 200mm.

For trench details refer Council Standard Drawings.

Sewers shall not be continuously surrounded with mass concrete, and shall preferably be surrounded with a minimum of 100mm of sand. Flexible joints shall be provided at least every six (6) metres. Concrete surround where/if approved by Council shall be as per Council standards.

### 1.3.2 PIPE AND MATERIAL SPECIFICATIONS

Refer MATERIALS Section of this Standard for pipe and materials specifications or as per the Council approved project drawings.

## 1.4 EXISTING SERVICES

The location of all existing services shall be confirmed with the appropriate Authority prior to the commencement of any excavation work. Where necessary test holes shall be excavated to confirm the precise locations of such services.

The contractor should also excavate and confirm the level of any existing sewer being connected to ensure that the design compliments field conditions. Council takes no responsibility for the accuracy of the As Constructed information supplied.

## 1.5 EXCAVATION

### 1.5.1 TRENCHING

All bracing, shoring, sheet piling or cages used to make the excavation safe shall be removed prior to backfilling. Every precaution shall be taken to prevent water entering excavations, and trenches shall be kept de-watered at all times.

For sewers more than 2.0 m deep, the maximum trench width shall be such that the gap between the sewer pipe and the trench walls does not exceed 200mm on either side. Where wider trenches are necessary (for safety cages etc), the trench shall be benched to avoid exceeding these limits adjacent to the pipe. The bottom bench shall extend not less than 300mm above the pipe obvert. Refer detail following.



## SEWERAGE DESIGN STANDARD

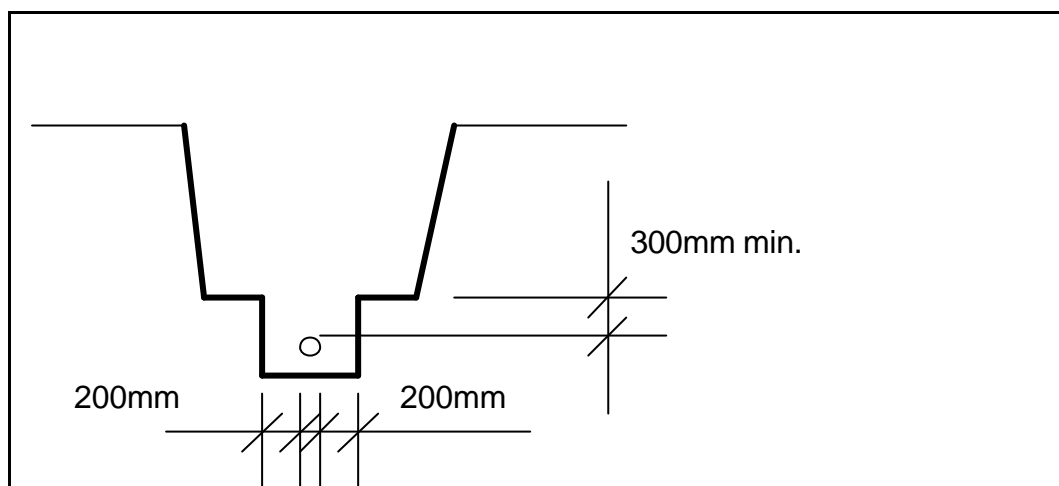

Where excavation exceeds the required depth by more than 200mm, the excavated material shall be replaced with stabilised sand or approved compacted fill to the required level.

All trenches shall be backfilled and reinstated to the satisfaction of Council and in the case of private property, the property owner.

### 1.6 PIPE LAYING AND JOINTING

For details of pipeline construction types including bedding for sewer pipe, refer Council standard drawing SDS-01. The following types of construction are to be used in the following applications;

- Type 1:- Construction type in most instances other than specified below
- Type 2:- Where the cover over the sewer is less than that specified in these standards, or where loadings greater than specified by the manufacturer for the type of pipe, or to guard against root invasion.
- Type 3:- Where the grade of the pipe is greater than 15%.
- Type 4:- Where the trench bottom is very soft.  
(filter material drain to stormwater where possible)
- Type 5:- Where the sewer is constructed under an existing road.

Refer to the SCOA for other details where applicable.

#### 1.6.1 PIPE LAYING & JOINING

In soft or wet ground, Council and/or the supervising engineer may require additional excavation and refilling with stone compacted in 100mm layers. In very poor conditions, Council may require geofabrics, or other means of providing a stable pipe bed. Refer Council standard drawing SDS-01 for alternative details.

## SEWERAGE DESIGN STANDARD

---

When connecting to existing systems other than via an existing maintenance hole, the existing line should be exposed prior to laying any new sewer line so that its position grade and level may be confirmed.

When pipe laying is not proceeding, the end of the laid pipes shall be covered to prevent ingress of foreign material.

Where house drainage connections are provided, that section of the sewer line shall be left exposed until the position of the slope junction and the end of the property connection have been recorded by the Surveyor for "as constructed".

### **1.6.2 JUNCTIONS, PROPERTY CONNECTIONS SEWERS, INSPECTION OPENINGS**

Junctions, property connections sewers, and inspection openings shall be constructed in accordance with Council Standard Drawings.

Property connections shall be provided as shown on the approved plans, using rubber ring jointed oblique junctions, 100mm diameter uPVC sewer pipe and bends in accordance with Council's standard drawing SDS-03.

Where property connections are provided from maintenance holes, a flexible joint shall be provided not more than 300mm from the face of the concrete wall, and the property connection extended at least 600mm from the side of the maintenance hole. Slip collars are not acceptable as flexible joints. These property connection branches should end at the correct location inside the serviced property.

All property connections shall be laid on a grade of at least 1:40.

### **1.6.3 INVERTED SYPHONS, WATER SEALS AND VERTICAL RISERS**

Inverted syphons, water seals and vertical risers may be constructed in accordance with SCOA where approved by Council.

### **1.6.4 DEAD ENDS**

Dead ends are usually not permitted unless approved by Council. Dead ends should then be in accordance with SCOA drawing SEW-304 .

### **1.6.5 MARKING OF PROPOERTY CONNECTIONS**

Property connections shall be marked in accordance Council Standard drawing SDS-03.

### **1.6.6 DETECTABLE TAPE**

Detectable tape is not required for non-metallic pipelines provided the 200mm of overlay embedment is provided to the pipe and the embedment is easily discernible from backfill or natural ground.

---

## SEWERAGE DESIGN STANDARD

---

### 1.6.7 BACKFILLING

Backfill in allotments and footpaths shall be compacted to 95% of maximum modified dry density as determined by Part E2.1 of Australian Standard AS 1289, "Methods of Testing Soil for Engineering Purposes". Refer Road Design Standard for compaction levels required under roads.

Where backfill is in acid sulphate soil, the disturbed soil shall be treated and neutralised in accordance with the requirements of Council or applicable State Planning Policy. Where practical, impermeable clay trench stops should be constructed at 35m centres along the trench to prevent the drainage and further oxidation of the acid sulphate soil. These stops should be through to the base of the trench substituting for the bedding sand in the immediate area.

## 1.7 MAINTENANCE HOLES

Maintenance holes shall be constructed in the positions and to the levels shown on the approved plans in accordance with Council standard drawing SDS-02.

Maintenance holes shall be constructed from pre-cast concrete components and fibreglass base liners. The use of cast-in-situ components and cement based mortar benching is not permitted except in maintenance holes over 1500mm in diameter or as expressly approved by Council.

### 1.7.1 MAINTENANCE HOLE CONNECTIONS

All sewer lines shall be connected to maintenance holes via special spigot or socket "shorts" which shall be cast into the maintenance hole wall. Cast-in shorts shall extend not more than 300mm from the concrete face.

All shorts shall be designed for a water tight seal and maximum grip on the concrete surface. uPVC shorts shall be fitted with ribs and coated with coarse sand.

Rubber ring socket joints shall be provided on all sewers and house drains connected to maintenance holes at not more than 300mm from the concrete face.

Maintenance holes constructed over existing AC sewer lines will have a fibreglass base installed where practical. The new maintenance hole shall be connected to the existing line with a short 300mm long rubber ring joint Class SN8 uPVC line on the upstream side and a short 300mm piece of class SN8 sewer line connecting to the existing downstream pipe with a long rubber ring gibault joint.

Where a future extension is planned, a stub shall be provided consisting of a short with a rubber ring joint protruding 300mm from the maintenance hole with a 500mm long short of pipe (with a glued cap) inserted onto the short.

### 1.7.2 MAINTENANCE HOLE BASES

Maintenance hole bases shall be poured on tight natural material or approved compacted fill using approved circular steel formwork with an internal diameter not less than 100mm greater than the outside diameter and 100mm above the bottom of the pre-cast wall sections. Concrete shall be poured level with the top of the form. Formwork allows easy future connections to the maintenance hole should it be needed.

---

**SEWERAGE DESIGN STANDARD**

---

The formwork shall be designed to fit tightly around incoming and outgoing sewers and the use of sandbagging is not permitted.

Where excavation below the base of the concrete pour exceeds 200mm, stabilised sand shall be used to bring the level back to the desired subgrade level.

Maintenance hole bases shall be poured so that air entrapment does not occur under the fibreglass liner. Holes of maximum diameter 6mm may be drilled in the fibreglass liner to assist in the removal of air pockets, and later filled and sealed with "Megapoxy" or equivalent. Minimum spacing of holes shall be 250mm. Over vibration and/or a concrete mix which is too wet are common causes of druminess. Bases which exhibit druminess shall be repaired by the injection of a cement based mortar mix into holes drilled into the base. These holes shall be plastered with megapoxy after the injection process.

The joints between sewer pipes or property connections and the concrete base shall be sealed with "Megapoxy" or equivalent.

**1.7.3 MAINTENANCE HOLE WALLS**

The joints between wall sections shall have a minimum working pressure of 100 kPa and shall be bonded with "Megapoxy" or equivalent.

All joints between pre-cast components including the joint between the fibreglass base liner, the first wall pipe, and the poured concrete base shall be sealed internally and externally around the full circumference with "Megapoxy" or equivalent.

Any holes required in the wall sections shall be neatly saw cut and all pipes passing through maintenance hole walls shall be held in place and sealed with "Megapoxy" or equivalent. Concrete drilling is the preferred method where possible.

Tapered wall sections and step irons shall not be used.

**1.7.4 CONVERTER SLABS AND MAKE-UP RINGS**

The converter slab shall be bonded to the top wall section with a 25mm layer of cement mortar. The surfaces shall be well roughened and wetted to ensure a good bond and water tight joint. The joint shall be internally and externally rendered and then sealed. The joint between the converter slab and the top wall section shall be sealed internally and externally with 2-3mm thick silicon. Where circular lids are installed, *the access opening shall be located directly over the outlet pipe*. Where a square lid is installed, the long sides of the opening shall be parallel to the downstream line.

The maximum depth between the top of the surround and the underside of the converter slab shall be 375mm. The joints between the make-up ring, the converter slab, and top shall be mortared and sealed with Megapoxy.

---

**SEWERAGE DESIGN STANDARD**

---

**1.7.5 MAINTENANCE HOLE COVERS AND FRAMES**

Maintenance hole covers, frames, and margins should be temporarily secured in place until the final earthworks profile is completed. Only when the finished earthworks, pavement and footpath profiles are complete should the tops and lids be fixed in a permanent manner *parallel* to the final surface profile protruding above the finished surface profile by the amounts shown on Council standard drawing SDS-02

Circular cast iron maintenance hole covers shall be provided in all trafficable areas and within road reserves.

Special watertight covers shall be installed where the maintenance hole is likely to be submerged by stormwater or flooding.

Concrete in-filled maintenance hole covers shall be imprinted with the words "SAN SEW" using a stamp or mould. These words shall be sharp and clearly inscribed. Poorly inscribed covers shall be rejected.

Maintenance hole covers shall be sealed with silicon after the sewers have been inspected and passed for on-maintenance.

**1.7.6 BACKDROPS**

Unless otherwise approved by the relevant Council, maintenance hole backdrops shall be internal for Calliope Shire Council and external drops for Gladstone City Council. Refer Council standard drawing SDS-02 for details.

The vertical drop section shall be constructed using glued uPVC pipe work (Class SN8) and fittings. Backdrops shall be secured to the maintenance hole wall using 25mm wide by 2.5mm thick stainless steel straps (grade 316) located at the top and bottom and one (1) metre intervals in between. Straps shall be secured to the walls using grade 316 stainless steel anchors of not less than 8mm diameter. The backdrop shall terminate with a 45 or 90 degree bend in the channel provided in the maintenance hole base. Backfill under the incoming pipe to be dropped in the maintenance hole shall be compacted to 95% AASHO.

Special designs are required for backdrops for pipes of 300mm or greater diameter. Larger maintenance holes are required where more than one back drop is contained in the maintenance hole.

External backdrops where approved by Council, shall be constructed using Class SN8 uPVC rubber ring jointed pipe and fittings. The full depth of the backdrop shall be encased in stabilised sand from the natural undisturbed material at the base of the maintenance hole, to the sewer main which shall be cradled to 50% of its depth. Stabilised sand backfill shall extend along the pipeline until the excavated depth below the sewer does not exceed 100mm. The width of the stabilised sand backfill and encasement shall be not less than four (4) times the pipe diameter.

---

**SEWERAGE DESIGN STANDARD**

---

**1.7.7 BACKFILLING MAINTENANCE HOLES**

Where maintenance holes are installed below RL5.0 or are likely to be in contact with acid sulphate soils, maintenance holes shall be backfilled using a limestone crusher dust material in order to neutralise any acid run off from contacting concrete components such as maintenance holes.

Where backfill is acid sulphate soil, the soil shall be treated neutralised in accordance with Council's requirements or applicable State Planning Policy.

**1.8 TERMINAL MAINTENANCE SHAFTS**

Terminal maintenance shafts shall be located in the positions shown on the approved plans and constructed in accordance with Council standard drawing SDS-02.

The terminal maintenance shaft margin set shall be finished 70mm above ground level if located within allotments, and 30mm above finished ground level in the road reserve.

**1.9 TOLERANCES ON AS CONSTRUCTED WORK**

Tolerances on as constructed works shall be generally in accordance with Section 12 of Part 4 of the SCOA.

**1.10 FILLING**

Refer Section 1.6.7 Backfilling of this Standard for compaction standards.

**1.11 RESTORATION & CLEAN UP**

All existing structures, fences, turf, concrete or paved surfaces, roads and paths, trees and other properties affected by the works shall be restored to a condition equivalent to that prior to the work.

Restoration shall be carried out progressively as each section of works is completed and all cleared vegetation, rubbish and spoil shall be removed from the site of the works and the area left in a neat and tidy condition.

The excavated and disturbed area shall be stabilised to minimise wind and water erosion of the restored area including any measures required by Council to achieve the objectives of Council's Environmental Management Plan. Measures required by Council may include turfing, silt fences, etc.

**1.12 EXISTING SEWERS**

Connection to existing sewers shall not be carried out unless the new sewers have been tested cleaned and approved in writing by Council for connection to the existing sewer. Connections to existing sewers shall be carried out by the Council at the cost of the applicant unless written permission is granted for connection to be made by a nominated contractor. The Contractor shall take all precautions to minimise inconvenience to the residences serviced by the existing sewer and the installation is to be carried out at times when sewage flow is likely to be at a minimum.

## SEWERAGE DESIGN STANDARD

---

Where oblique junctions are to be cut into existing sewers, Council shall be notified prior to carrying out the work. The existing sewer shall be carefully exposed for at least 1 metre along the line at the location where a junction is to be installed and a minimum of 150mm excavated from under the pipe.

Testing plugs shall then be inserted and the existing sewer line air tested for leaks. If the test is successful the line shall be neatly cut, the ends chamfered and burrs removed, and the junction installed by means of slip couplings.

The line is then to be retested, inspected and the location and level of the new junction recorded prior to backfilling with compacted sand.

Should the existing sewer fail to pass the first air test, Council will advise of any further requirements.

### 1.13 "AS CONSTRUCTED" DETAILS

Works "as constructed" details shall be provided in accordance with the relevant section of Council's *"Engineering and development Guidelines"*.

Preliminary As-constructed information showing the location of all sewer mains and house connections is required prior to Council endorsing the Plan of Reconfiguration .

Final As-constructed information showing all sewer detail is required prior to Council accepting the works on-maintenance. Refer Appendix B for detailed specification of as-constructed details required.

### 1.14 SUB-SOIL DRAINAGE

Council may require sub-soil drainage to be provided at the low point in sewerage trenches and/or around maintenance holes where the water table is higher than the sewer line or where the sewer line passes through an underground stream. This sub-soil drainage shall be connected to the stormwater pipe system as directed by Council.

### 1.15 ROAD CROSSINGS

Except where otherwise approved by Council, all sewer crossings under existing sealed pavements shall be carried out by under-road boring. The bored hole shall be on the correct line and grade and sleeved with a ductile or cast iron pipe with an internal diameter of not more than 25mm larger than the external diameter of the sewer pipe (measured across the socket).

The cavity between the sewer and the sleeve shall be concrete grouted under pressure, and flexible joints shall be provided at either end of the sleeve, clear of, but not more than 150mm from the ends.

Sewer crossings of gravel roads may be trenched provided the sand surround has been compacted to 95% AASHO standard compaction and the trench is backfilled to surface level with stabilised sand. This backfill shall extend through any table drains either side of the road. The minimum cover for sewers under roads applies to the table drains of roads without kerb and channel.

Backfill across access tracks and driveways shall consist of stabilised sand to a depth of 200mm below finished ground level, and gravel placed and compacted to the surface.

---

**SEWERAGE DESIGN STANDARD**

---

**1.16 WATER COURSES**

The minimum cover of sewers under water courses with standard trenching methods is 1.0m. Concrete backfill (15 MPa) shall be provided for any sewer which may be exposed by scouring of water courses or gullies. The concrete backfill shall extend from 300mm above the sewer to the water course level.

Where a sewer line does not comply with the minimum cover or is required to be exposed through a gully, the details of such arrangements shall be approved by Council on a case by case basis. As a guide, the pipes not subjected to salt water or acid sulphate runoff shall be DICL pipe class 12 supported by and secured to a concrete structure at 2.0m intervals.

**2 OTHER REQUIREMENTS****2.1 ENTRY ONTO PRIVATE LAND**

If it is necessary to enter existing allotments for the purpose of sewer construction, the necessary permission shall be obtained and the owners given reasonable notice of the commencement of work in their property. Should the owners of the property refuse entry to the Contractor, Council may assist the developer in legally gaining access to the property to carry out the works.

The condition of the land should be recorded (preferably photographed) prior to entry, and where easements already exist, construction activity shall be confined to the easement wherever possible. At the completion of the work, the land shall be restored, and a written release obtained from the owner prior to the estate being placed on maintenance.

**2.2 INSPECTION AUDITS**

The supervising consulting engineer shall instruct the persons constructing the works to arrange the inspection of the works by the supervising engineer and a Council inspector at the stages listed below.

At least twenty four hours notice of the inspection is required. Council may decline the inspection however the supervising engineer shall attend every inspection and certify the works in accordance with section 2.3 of this standard.

The works shall be inspected at the following critical stages of construction:

1. Sand surround and Maintenance holes prior to backfilling,
2. Pressure testing,
3. On-maintenance, and
4. Off-maintenance.

At all of the above inspections, the location of the property boundary shall be clearly pegged to ensure correct alignment and locations. The supervising consulting engineer shall inspect the works as per the following list, with the relevant Council officer also invited to attend each inspection.



**SEWERAGE DESIGN STANDARD****2.3 CERTIFICATION BY SUPERVISING CONSULTING ENGINEER**

The supervising consulting engineer shall inspect and certify that the works have been inspected and carried out in accordance with the requirements of this standard. The standard pro-forma supplied in Appendix A shall be used for each inspection, as well as any documentation volunteered by the consultant.

Certification of each inspection shall be submitted to Council within two days of carrying out the inspection. The subdivision will not be accepted on to the maintenance period if these certificates are not submitted to Council in accordance with the above requirements.

To assist the supervising consulting engineer in certifying the works, an Inspection And Testing Plan maybe required to be completed by the contractor, similar to that contained in Appendix A of the SCOA.

**2.4 MAINTENANCE PERIODS**

The work shall be maintained for a period of 12 months from the date it is accepted on-maintenance by Council. During the maintenance period, the developer shall make good any defects which appear in the work. Rectification of defects shall be completed within 7 days of being notified by Council. Should the necessary repairs not be carried out within the specified time, Council may carry out the work and deduct the cost from the Maintenance Bond lodged by the developer.

The commencement of the maintenance period may be delayed by the following not occurring **within 4 weeks** of the acceptance of the works for the maintenance period:

1. Rectification or completion of outstanding requirements from the works acceptance.
2. The plan of survey not endorsed by Council.
3. Final "as constructed" plans of the sewerage infrastructure are submitted to Council not being received within 4 weeks of on maintenance inspection.

Council may extend the maintenance period if;

1. The works have not been performed satisfactorily.
2. Substantial use of the infrastructure or development of the adjacent land has not occurred.
3. Certified as-constructed plans of all infrastructure including power and telephone have not been accepted by Council, or
4. The Plan of Survey over the subject land has not been registered at the expiration of the specified maintenance period.

**APPENDIX A – Design and Construction Proforma**

SEWERAGE DESIGN STANDARD

**SEWERAGE DESIGN CHECKLIST**

**Development Name:** \_\_\_\_\_ **Stage:** \_\_\_\_\_ **Date:** \_\_\_\_\_

- Sufficient detail and dimensions to construct reticulation system.....
- Layout and sizes as per Council requirements or conditions with adequate capacity.....
- Mains and house connection branch serve and control all allotments.....
- Depth of main to allow for future extension of the system.....
- Works noted to be in accordance with Council’s Sewerage Design Standard .....
- Appropriate Council and SCOA standard drawings included in documentation.....
- Pipe sizes are either, 150mm, 225mm etc with grades steeper than minimum.....
- Pipes uPVC RRJ class SN8 and pipe & embedment details supplied .....
- Alignment specified from the property boundaries appropriate to Council area.....
- Sewers located on opposite side of road to water reticulation .....
- Sewer lines within properties to be 1.5m from boundary, MH > 1.5m from boundary.....
- Sewers are laid parallel to or at 90 degrees to property boundaries.....
- Maintenance holes at changes of directions and 150mm pipe-100m, 225mm-150m.. .....
- Minimum depth of maintenance hole 1.2m, absolute minimum 900mm deep.....
- Pipe cover minimum: 1.2m arterial roads, 750mm roads & frontage, 600mm elsewhere.....
- Terminal maintenance shafts line not longer than 45m, grade for velocity 0.3m/s.....
- Pre-cast maintenance holes specified with converter slabs and fibreglass bases.....
- Pipe embedment details specified - trench types grading, colour, tape, roads crossings.....
- All other services and house connection branches plotted on long sections. ....
- Stainless steel specified for all bolts, fixtures, straps etc .....
- Works inspection plan included.....
- Acid sulphate soils addressed in design, or covering letter.....

I \_\_\_\_\_ of \_\_\_\_\_

RPEQ No.: \_\_\_\_\_ DATE: \_\_\_\_\_ Certify compliance with the relevant standards and work is completed as per the check list above.

Council use only:

SEWERAGE DESIGN STANDARD

**EMBEDMENT, HOUSE CONNECTION AND MH BASE INSPECTION CHECKLIST**

**DEVELOPMENT :** \_\_\_\_\_ **Stage:** \_\_\_\_\_ **Inspection Date:** \_\_\_\_\_

**Line fronting Lots:** \_\_\_\_\_ **Sewer lines:** \_\_\_\_\_

**Contractor Requirements:** 24 hours notice for inspection. For the section of pipe to be inspected, pipes to be embedded prior to back fill, all property connection branches in place and left uncovered, maintenance hole bases ( fibreglass in place) and ready for pouring, and sand levelled and compacted. Proposed property pegs in place.

**Controlling documents: Specification:** \_\_\_\_\_

**Drawings & rev.:** \_\_\_\_\_

**Other:** \_\_\_\_\_

**Items certified by SUPERVISING CONSULTING ENGINEER:**

- Pipe sizes, jointing and class as per Council requirements and approved documents.....
- Pipes are handled, stored and installed in accordance with manufacturer’s spec .....
- Pipe alignment from boundary as per Council standards and tolerances.....
- Sand bedding complies with grading in standard and is free of contaminants .....
- Embedment bedding and overlay compacted, level and 200mm over pipe.....
- Sight down sewer lines is straight horizontally and vertically.....
- Concrete maintenance hole bases bear on solid ground, short pipes to all sides.....
- Maintenance hole base form work to correct height and clearance from wall section.....
- Property connection branches 1m from either boundary with marker tape attached .....
- Copies of concrete docket attached from works.....
- Erosion and sediment control in place and operating effectively, Acid soils managed.....
- Variations to control documents, noted defects & instructions recorded in report .....

I \_\_\_\_\_ of \_\_\_\_\_

RPEQ Number: \_\_\_\_\_ have inspected the works and certify compliance with the relevant standards, approved documents and work is completed as per the check list above.

Date: \_\_\_\_\_

Council use only: \_\_\_\_\_

Report Attached

Defective works rectified and inspected .....  Date: \_\_\_\_\_

SEWERAGE DESIGN STANDARD

**ON MAINTENANCE CHECK LIST**

**DEVELOPMENT NAME:** \_\_\_\_\_ **Stage:** \_\_\_\_\_

- All works carried out to Council/SCOA standards, and approved drawings.....
- Materials and fittings used comply with the relevant Australian and Council Standards.....
- Sewers backfilled to required standard and compaction tests submitted to Council. ....
- Sewers flushed & clean, gas fit lids cleaned and grease seals completed, connection to existing sewer lines approved and made.....
- Pressure tests for mains & maintenance holes passed and report and results attached.....
- Maintenance hole joints completed sealed inside with epoxy or silicone as per standard ....
- Maintenance hole covers at grade and at level required to suit surrounding ground. (75mm in lots, 25mm footpaths, 2mm paved surfaces).....
- Where sewers are in developed areas existing surfaces restored after construction .....
- "As constructed" information submitted to Council, Plan of Reconfiguration registered .....
- Internal drops supported by stainless steel straps and fixtures, fixtures to wall sealed.....
- Pipes remain straight and round after back filling, HCB location tapes visible at surface .....
- Trenches compacted to standard, compaction & concrete testing submitted to Council.....
- Inspection and testing plans complete and attached (optional).....
- Copies of dockets for concrete batches, pipe and fittings submitted to Council .....
- Previous certified Check lists submitted to Council .....
- Variations to control documents, noted defects & instructions recorded in report .....
- Report Attached .....

Defective works rectified and inspected .....  Date: \_\_\_\_\_

I \_\_\_\_\_ of \_\_\_\_\_

RPEQ Number \_\_\_\_\_ certify work are completed as per the above check list in compliance with the Development Permit for Reconfiguration, Council's standards and relevant Australian Standards. Council use only Ver: \_\_\_\_\_

Attached documents: \_\_\_\_\_  
\_\_\_\_\_  
\_\_\_\_\_  
\_\_\_\_\_

SEWERAGE DESIGN STANDARD

**OFF MAINTENANCE CHECK LIST**

**DEVELOPMENT NAME:** \_\_\_\_\_ **Stage:** \_\_\_\_\_

- Final "as constructed" plans submitted to and accepted by Council .....
- Trenches have not subsided or subsidence repaired.....
- Final inspection of sewerage infrastructure undertaken as required by Council to ensure works are in good order and still in accordance with approved drawings design standards and Australian Standards before Council inspects works.....
- Land stabilised so that temporary erosion and sediment measures can be removed .....
- Maintenance hole covers above surrounding ground as per standard, and not disturbed .....
- Maintenance holes remain water tight or are resealed to ensure no infiltration.....
- Sewer pipes remain as designed at grade and circular without settlement or pondage.....
- Sub soil drains installed to problem areas.....
- Confined spaces entered for repairs or inspections in compliance with Australian Standard and Workplace Health & Safety requirements.....
- Defects noted & instructions recorded in report.....

I \_\_\_\_\_ of \_\_\_\_\_

RPEQ Number: \_\_\_\_\_ certify compliance with the relevant standards and work is completed as per the check list above. Council use only: \_\_\_\_\_

Report Attached .....

Defective works rectified and inspected .....  Date: \_\_\_\_\_

SEWERAGE DESIGN STANDARD



---

**APPENDIX B – Standard Drawings**

SEWERAGE DESIGN STANDARD

Std. Dwg. No.	Descriptions
<b>SDS-01</b>	<p align="center"><b>SEWER CONSTRUCTION</b></p> <p>Sewer Pipeline Construction Types</p>
<b>SDS-02</b>	<p align="center"><b>ACCESS CHAMBERS</b></p> <p>Access Chamber 1050mm DIA. Precast Components</p>
<b>SDS-03</b>	<p align="center"><b>HOUSE CONNECTION BRANCHES</b></p> <p>House Connection Branches</p>
<b>IMEAQ S-0070</b>	<p align="center"><b>PRESSURE MAIN</b></p> <p>Pressure Main Discharge Details</p>

		<table border="1"> <tr> <td colspan="2">SCALE</td> </tr> <tr> <td>DRAWN</td> <td>S.G.MCDONALD</td> </tr> <tr> <td>DRAWING CHECK</td> <td></td> </tr> <tr> <td>DESIGNED</td> <td>G.J.PENHALGON</td> </tr> <tr> <td>APPROVED</td> <td></td> </tr> </table>	SCALE		DRAWN	S.G.MCDONALD	DRAWING CHECK		DESIGNED	G.J.PENHALGON	APPROVED		<p align="center"><b>STANDARD DRAWINGS INDEX - SEWERAGE</b></p>	<table border="1"> <tr> <td>DATE</td> <td>SEPT. 2002</td> </tr> <tr> <td>DRAWING NUMBER</td> <td><b>SDS-00</b></td> </tr> <tr> <td>REVISION CODE</td> <td></td> </tr> </table>	DATE	SEPT. 2002	DRAWING NUMBER	<b>SDS-00</b>	REVISION CODE	
SCALE																				
DRAWN	S.G.MCDONALD																			
DRAWING CHECK																				
DESIGNED	G.J.PENHALGON																			
APPROVED																				
DATE	SEPT. 2002																			
DRAWING NUMBER	<b>SDS-00</b>																			
REVISION CODE																				



SEWERAGE DESIGN STANDARD

**TYPE 1**

Standard trench width

Natural Surface

Backfill

Pipe bedding

Concrete slab 750 thick (specify as per project drawings)

**TYPE 2**

Standard trench width

Natural Surface

Backfill

Steel Reinforcing

Alternative bedding

Concrete Slab

Pipe bedding

**TYPE 3**

Standard trench width

Natural Surface

Backfill

Pipe bedding

Concrete slab 750 thick (specify as per project drawings)

**TYPE 4**

Standard trench width

Natural Surface

Backfill

Pipe bedding

Filter Fabric (Refer Note 2)

Crushed rock or grit as specified

**TYPE 5**

Standard trench width

Natural Surface

Backfill

Additional size of an additional layer of backfill

25 MM - 10 MAX coarse aggregate

Trench roof - Bitumen and spray rate 1.5L/m<sup>2</sup>

Lean mix concrete

Sand surround

Notes:

1. Pipe bedding classification:
  - (a) Light Pipes: Lightly ram, fibre cement and concrete.
  - (b) Flexible Pipes: Unplasticized polyethylene, glass fibre reinforced thermoplastic, aramid fibre, fibreglass, polypropylene, polyethylene and polyethylene.
2. An approved geotextile fabric shall be used in all trenches around outside rock pipe bedding.
3. The road surface finish shall be aggregate concrete or other surface specified in the project drawings or by the Superintendent.
4. Reinforcing under roads shall be lean mix (200) low slump concrete for an approved equivalent compacted in lifts at 125 to 150mm.
5. Sand surround compacted in 150mm layers to 75% D.L. or 85% standard compaction in bedding and side support. Density index (D.I.) as per A.S. 2891 (A.1). Standard compaction as per A.S. 2891 (A.1).
6. Concrete (N1) in accordance with AS 1079 and AS 3600.
7. All dimensions in millimetres.

**UNDER EXISTING ROADS**

AMENDED REF:AO DWG 5-2076

SCALE: NOT TO SCALE

DRAWN: S.G. McDONALD

CHECKED: S.G. McDONALD

DATE: SEPT 02

DESIGNED: C.J. PENHALGON

AMENDMENTS	
NO.	DESCRIPTION

SDS-01

REVISION CODE: A

**SEWERAGE DESIGN STANDARD**

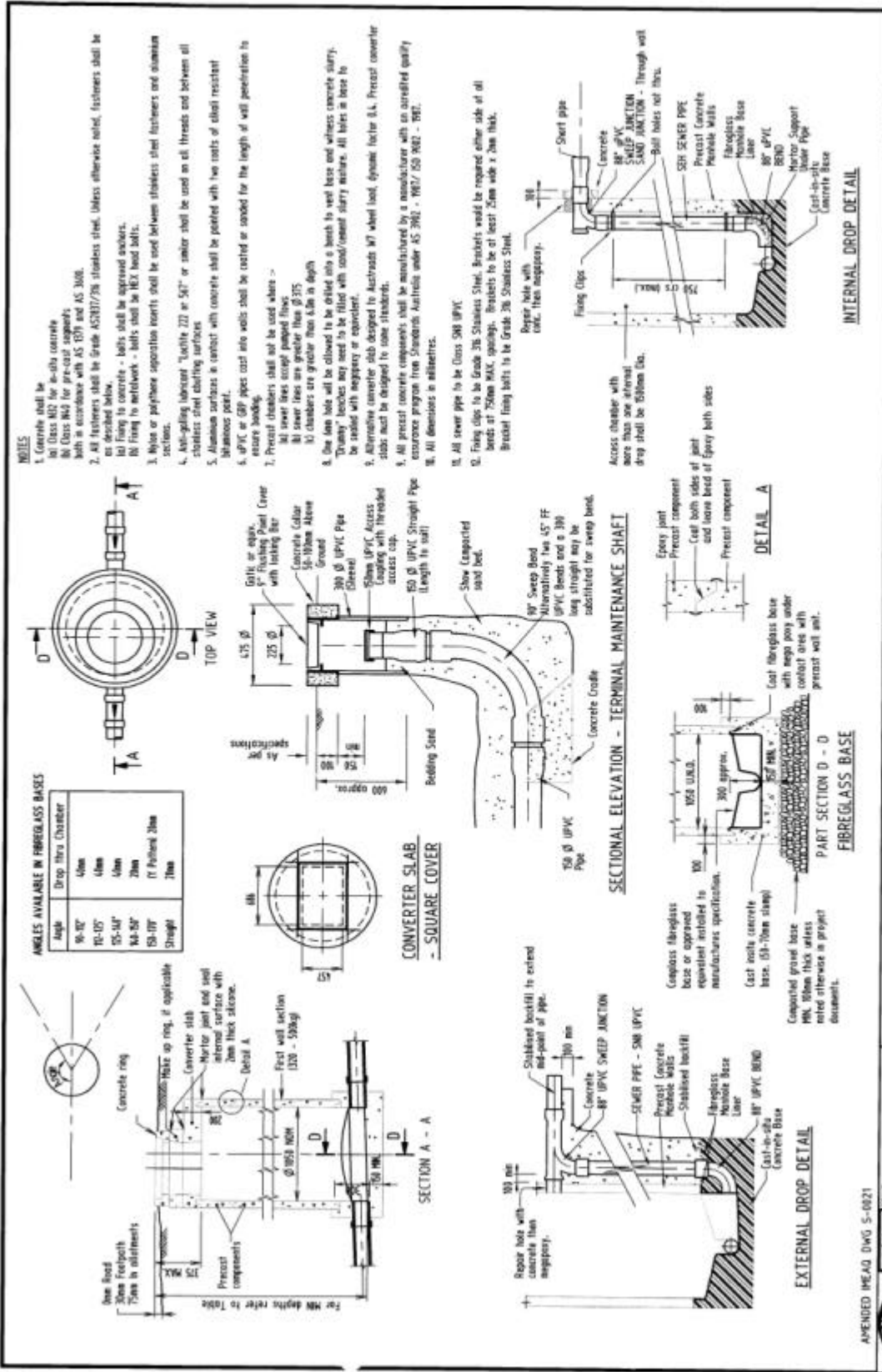

- NOTES**
- Concrete shall be:
    - (a) Class M42 for in-situ concrete
    - (b) Class M42 for pre-cast concrete
    - (c) Class M42 for pre-cast concrete with a reinforcement with AS 1921 and AS 3008
  - All fasteners shall be Grade A520B17/78 stainless steel. Unless otherwise noted, fasteners shall be an stainless steel.
    - (a) Flang to concrete - bolts shall be galvanized.
    - (b) Flang to metalwork - bolts shall be HEX head bolts.
  - Nylon or polythene separation inserts shall be used between stainless steel fasteners and aluminium sections.
  - Anti-splint lubricant such as Teflon 222 or 522 or similar shall be used on all threads and between all stainless steel cladding surfaces.
  - Aluminium surfaces in contact with concrete shall be primed with two coats of oil resistant stainless steel cladding surface.
  - UPVC or GFR pipes cast into walls shall be coated or sanded for the length of wall penetration to ensure bonding.
    - (a) Pre-cast chambers shall not be used where:
      - (i) sewer lines slope up to 1%
      - (ii) sewer lines are greater than 4.5m in depth
      - (iii) chambers are greater than 4.5m in depth
  - One line hole will be allowed to be drilled into a bench to vent base and witness concrete slurry. "Dummy" locates may need to be filled with coal/cement slurry mixture. All holes in base to be sealed with neoprene or equivalent.
  - Alternative chamber slab design to Australia M7 wheel load, dynamic factor 1.1. Precast concrete slabs must be designed to some standards.
  - All precast concrete components shall be manufactured by a manufacturer with an accredited quality assurance program from Standards Australia under AS 2902 - 1982 / AS 2902 - 1982 - 1982.
  - All dimensions in millimetres.
  - All sewer pipe to be Class SM UPVC.
  - Filing clips to be Grade 316 Stainless Steel. Brackets will be required either side of all bands at 200mm M&K spacing. Brackets to be at least 25mm wide x 20mm high. Precast filing clips to be Grade 316 Stainless Steel.
    - (a) Paper hole with 10mm diam. from neoprene.

AMENDMENTS			DATE		BY	
NO.	DESCRIPTION	DATE	INITIALS	DATE	INITIALS	SR
B	ADDITION OF EXTERNAL DROP DETAIL	L/19/02	SGP			

SCALE	<b>NOT TO SCALE</b>
DRAWN	S.G. McDONALD
FILE	SDS-02.DWG
DATE	OCT 02
CHECKED	G.A. PENNINGTON

  

		SDS-02 REVISION CODE <b>B</b>
<b>MAINTENANCE HOLES DETAILS AND TERMINAL MAINTENANCE SHAFT</b>		

APPENDED HEAD DWG S-0821

SEWERAGE DESIGN STANDARD

APPROVED INEAG DWG S-4038



SCALE: **NOT TO SCALE**

DRAWN	S.G. McDONALD
FILE	SDS-03.dwg
DATE	SEPT 02
DESIGNED	G.J. PENNELL/DCM

AMENDMENTS		DATE	INTL
	DESCRIPTION		

HOUSE CONNECTION BRANCHES

SDS-03

REV. DRAWING NO. REVISION CODE **A**

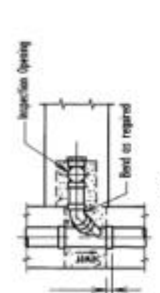

**PLAN**

Refer note 5.

House drain

House Connection Branch

Concrete

45° Junction

Refer note 5.

Bed as required

18 to 20% vertical drop

**ELEVATION TYPE A**

**SLOPED H.C. BRANCH**

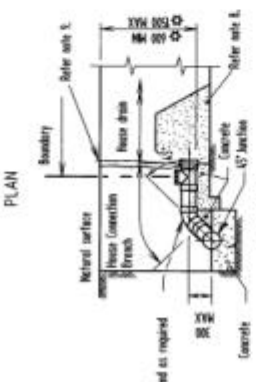

Refer note 5.

House drain

House Connection Branch

Concrete

45° Junction

Refer note 5.

Bed as required

18 to 20% vertical drop

**ELEVATION TYPE A**

**SLOPED H.C. BRANCH**

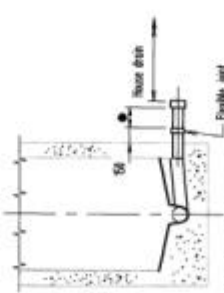

**INLET TYPE AC**

House drain

Flexible joint

**PLAN**

Refer note 5.

House drain

House Connection Branch

Concrete

45° Junction

Refer note 5.

Bed as required

**ELEVATION TYPE B**

**SLOPED H.C. BRANCH**

(Vertical drop >30% to <200)

**PLAN**

Refer note 5.

House drain

House Connection Branch

Concrete

45° Junction

Refer note 5.

Bed as required

**ELEVATION TYPE C**

**VERTICAL H.C. BRANCH**

(Vertical drop 100% and above)

**PLAN**

Refer note 5.

House drain

House Connection Branch

Concrete

45° Junction

Refer note 5.

Bed as required

**ELEVATION TYPE C**

**VERTICAL H.C. BRANCH**

(Vertical drop 100% and above)

**NOTES**

- Concrete landing access chamber: R3 in accordance with AS 1579 and AS 3488.
- Pipe materials and fittings shall have a "Standard Mark" under the National Plumbing Verification Scheme.
- Where rigid pipes are used in sewers a 500 long pipe shall be located on each side of the house connection branch.
- All dimensions in millimetres.
- House connections from sewer main in footpath to be reinforced to be inside of front/rear boundary and be horizontal up till of side boundary.
- All joints to be UPVC Class 200.
- Diameter of house connection branches shall be 100mm unless noted otherwise in the project drawings.
- Place 200mm of compacted sand over end of house connection pipe.
- Contractor to keep yellow marking tape around end of house connection branch during backfilling. Tape to be removed off of connection prior to finish.

**LEGEND**

- The maximum depth to the inspection pipe may be varied only if there is sufficient cover to serve the block.
- Slab length 3.0meters - Refer also note 5.
- grade of 1 in 60.

## SEWERAGE DESIGN STANDARD

**INDEX**

<b>A</b>		<b>M</b>	
As-constructed.....	16	Maintenance Hole	
<b>B</b>		Back drops.....	14
Backfilling.....	12	Bases.....	12
Backfilling Maintenance holes.....	15	Construction.....	12
Bedding.....	9	Covers and Frames.....	14
Bedding Material		Location.....	3
SEE EMBEDMENT MATERIAL.....	6	Minimum depth.....	3
<b>C</b>		Walls.....	13
Concrete.....	6	Maintenance period.....	18
Converter Slabs.....	13	Make-up Rings.....	13
<b>D</b>		Manhole	
Detectable Tape.....	11	see maintenace structures.....	2
Drawing Requirements.....	4	Materials	
<b>E</b>		Pipes, maintenance holes etc.....	5
Embedment material.....	6	<b>P</b>	
Excavation.....	9	Pipe grades.....	2
EXISTING SERVICES.....	9	Pipe LAYING AND JOINTING.....	10
Existing sewers		Pipe sizes.....	2
Connection to.....	15	PRIVATE LAND.....	17
<b>F</b>		Property Connections	
Flow estimation.....	5	Construction.....	11
<b>G</b>		Marking.....	11
Gibault		Pump stations.....	5
Sewer.....	6	<b>R</b>	
<b>H</b>		RESTORATION & CLEAN UP.....	15
House Connection		<b>S</b>	
See Property Connection.....	11	Stabilised sand.....	6
<b>I</b>		Standard Drawings.....	7
Inspection shafts		Sub-soil drainage.....	16
See terminal maintenance shaft.....	4	<b>T</b>	
Inspections.....	8, 17	Terminal maintenance shafts.....	4
<b>L</b>		Construction.....	15
Layout and alignment.....	2	Testing.....	8
Licensed persons.....	8	TOLERANCES ON as constructed WORK.....	15
		Trenching	
		Under roads.....	16
		<b>W</b>	
		Water Agency.....	v
		Water courses	
		Sewer crossing.....	17

## SEWERAGE DESIGN STANDARD

---

### **DOCUMENT INFORMATION**

File name: SEWERAGE DESIGN STD 2001.doc

File Location: H:\...\GREG\planning scheme docs\leng & development guide\

Author: Greg Penhaligon

Public Release Information :

Status	Release	Document Name	Date
Draft	Water Supply & Sewerage Guidelines	Wat& Sew3.doc	16/1/96
B4 council	Sewerage Design Standard	SEWERAGE DESIGN STD 2001.doc	4/9/02
Adopted and issued	Sewerage Design Standard 2003	SEWERAGE DESIGN STD 2001.doc	12/2002

Related files:

Check list for design purposes:

### **Special Document Notes:**

1. Blank pages required for double sided printing.
2. Doc set up for printing on the Konica copier printer. Adjustments may be needed for other printers.